

Series 94152

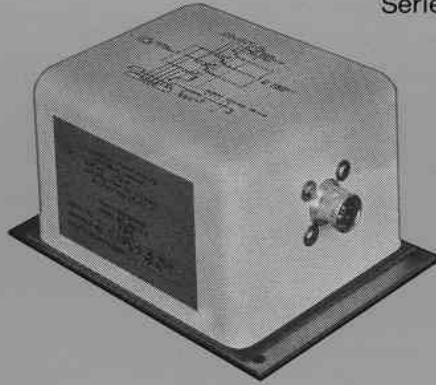

MIL-APPROVED POWER MONITORS QPL per MIL-E-0024021F

- Phase Detection
- Over/Under Voltage Sensing
- Over/Under Frequency Sensing
- Time-Out per MIL-STD-704

QPL-approved Power Monitors designed to meet the requirements of MIL-STD-704 for aircraft and missile applications. Provide solid-state sensing of over or under-voltage, over or under-frequency, and phase sequence condition of 115V, 400Hz power sources.

APPLICATION The BC Systems Series 94152 Power Monitor is a sensing device designed for installation in aircraft. It senses the output characteristics of the 115V, 400Hz ground power source and protects the aircraft's AC distribution system and equipment from over or under-voltage, over or under frequency, or improper phase sequence. The output of the Power Monitor controls the coil circuit of the aircraft's AC contactor. Any out of specification condition will de-energize the contactor. (See External Circuit Diagrams on the other side of this sheet.)

DESCRIPTION & OPERATION Two standard models are offered: BC Systems Model 94152-2 and 94152-4 (MIL Part No. M24021-2 and M24021-4 respectively). The principal difference between the two models is that the -2 output is a nominal 26VDC between connector pins 4 and 5, while the -4 output is a switch closure between pins F and H. Other differences are shown below:

	94152-2	94152-4
	(M24021-2)	(M24021-4)
Output	26 ±4VDC	Switch Closure
Connector	MS3137-7S	MS3116-12-10S
Weight, max.	2.5 lbs.	2.0 lbs.
Dimensions	3.00"x4.00"x5.50"	3.00"x4.00"x5.50"

BC Systems Series 94152 Power Monitors are completely solid-state devices employing all military-approved components. They sense the condition of a 115V, 400Hz power source and determine its acceptability in terms of MIL-STD-704. If the condition of the 115V, 400Hz input power varies from the specified limits, the Power Monitor's output circuit will open and remain open until reset. The output circuit can be used to drive an AC contactor or any other control device.

The functional block diagram shown below illustrates the operation of the Power Monitor modules:

- . If the input power is not phase A.B.C. or B.C.A. the output will not be actuated.
- . If the input voltage is over or under frequency, the timer T2 will start and the output will deactuate after 1 second if the frequency has not returned to the specified range.
- . If the input voltage is above 130 volts or below 100 volts the timers T1 and/or T2 will start and time out proportionate to the degree of deviation from the nominal, in accordance with the voltage transient curve of MILSTD-704 (See other side of sheet).

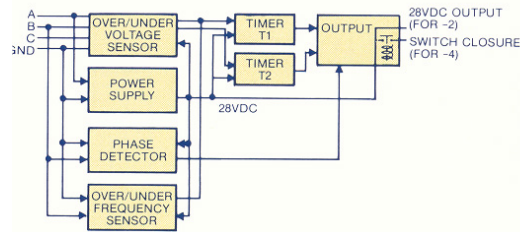

RELATED PRODUCTS BC Systems also produces a complete line of related products such as special purpose power monitors, voltage sensors, frequency sensors, phase detectors, and electronic timers. For complete information, contact BC Systems directly or through the local sales representative.

BC Systems Inc.

200 Belle Mead Rd., Setauket N.Y. 11733
(631)-751-9370 Fax (631)751-9378

www.bcpowersys.com



Series 94152 POWER MONITORS

FREQUENCY & VOLTAGE OPERATING VALUES

FUNCTION	STEADY-STATE OPERATION			TRANSIENT OPERATION		
	OPERATING RANGE	RESPONSE TIME, sec.		OPERATING RANGE	RESPONSE TIME, sec.	
		Drop Out	Pick Up		Drop Out	Pick Up
OVER-FREQUENCY	425-430Hz	1.0 ± .25	0.5 ± 0.5	Above 430Hz	1.0 ± .25	0.5 ± 0.5
UNDER-FREQUENCY	370-375Hz	1.0 ± .25	0.5 ± 0.5	Below 370Hz	1.0 ± .25	0.5 ± 0.5
OVER-VOLTAGE	125-130V	1.0 to 3.0	0.5 ± 0.5	Between 130V and 174V Above 174V	Limit 1*, +200%, -0% Less than 0.03	0.5 ± 0.5 0.5 ± 0.5
UNDER-VOLTAGE	100-105V	.85 to 2.55	0.5 ± 0.5	Below 100V	Limit 2*, +200%, -0%	0.5 ± 0.5

*See curves below

VOLTAGE TRANSIENTS

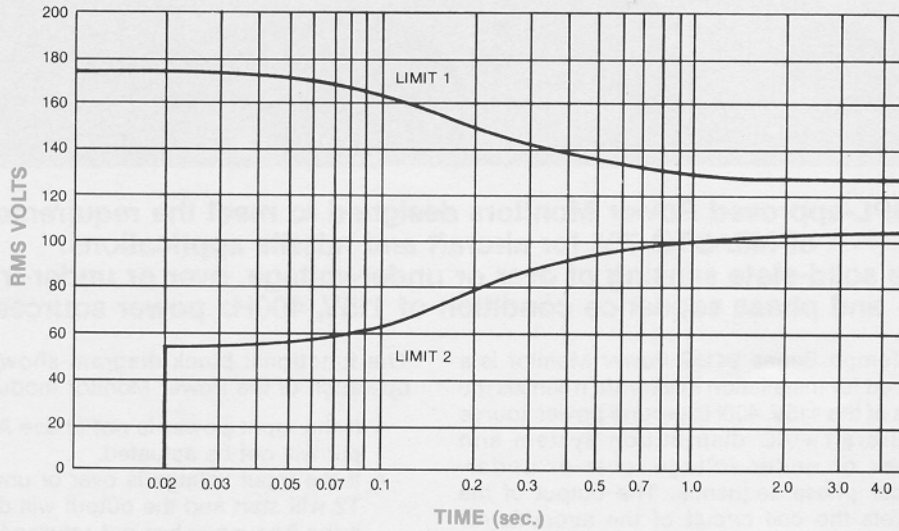

OUTLINE DIMENSIONS

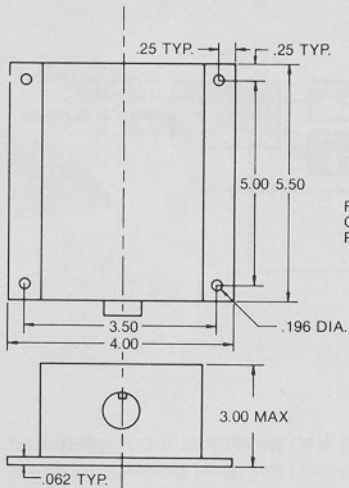

EXTERNAL CIRCUIT DIAGRAMS

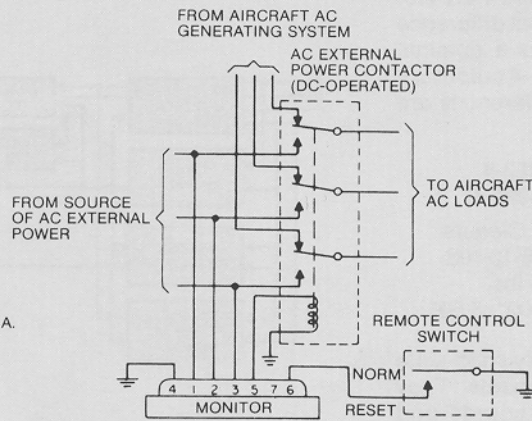

Model 94152-2 (M24021-2)

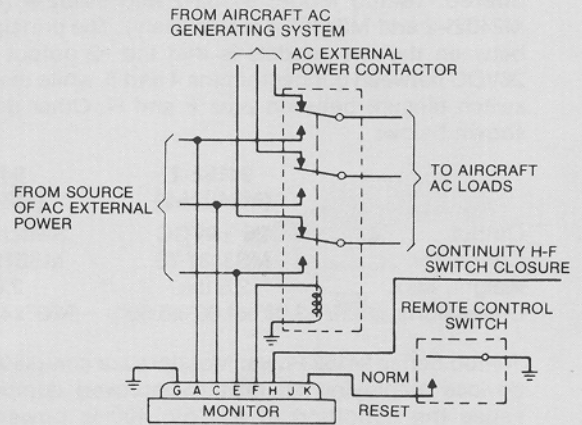

Model 94152-4 (M24021-4)

BC Systems Inc.

200 Belle Mead Rd., Setauket N.Y. 11733

(631)-751-9370 Fax (631)751-9378

www.bcpowersys.com